

KITS FOR THE DTSS MACHINES

1. 2 flat-outlets Kit
2. LAA 200 Long Range and Height Cannon
3. Ø200 Double Cannon
4. 4 outlets Kit
5. 4 fan-outlets Kit
6. California Kit
7. 4 or 6 fan-outlets kit
8. 12 meters row crops boom
9. LAA 300 Long Range and Height Cannon 80°

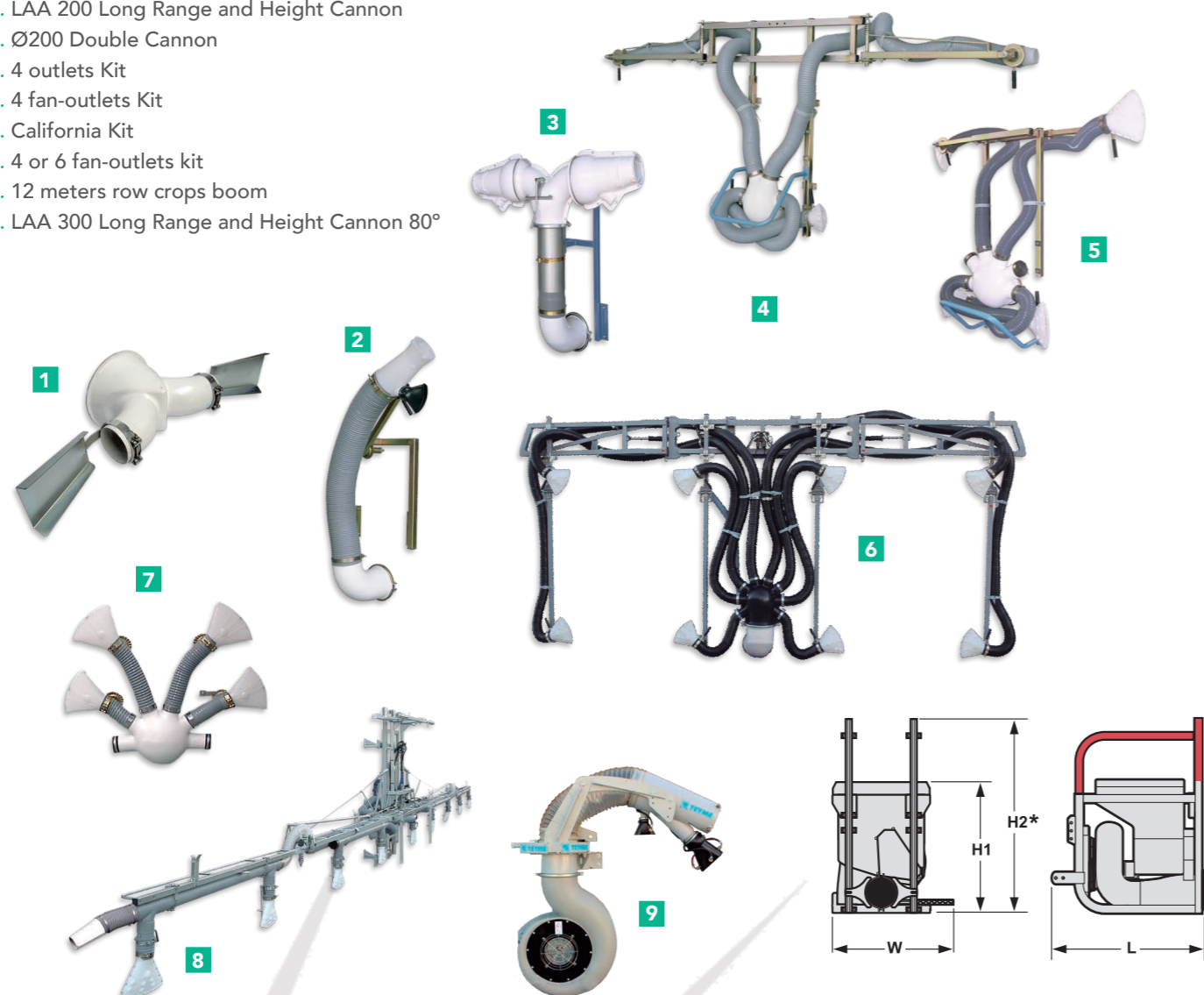

Model	Hopper l	L mm	W mm	H1 mm	H2 mm	Tare kg
DTSS 660	660	1.543	1.250	1.500	1.997	470

* DTSS 770 AirDust model dimensions reckoned with reinforcing iron arches and high guides. Just needed in case of adapting booms for treatments from 4 to 18 meters.

DTSS700

AIR DUST

DUSTERS



TEYME'S RANGE OF PRODUCTS

Mistblowers

Pneumatic sprayers

Dusters

Boom sprayers

Sprayers

Humidification and ventilation

TEYME

Pol. Ind. SAU III · C/ Girona, 2
25131 TORRE-SERONA (Lleida) · SPAIN
T: (+34) 973 75 00 33 · F: (+34) 973 75 15 81
comercial@teyme.es

www.teyme.es



DEALER:

TEYME reserves its own right to modify, without prior notice, features and performances of the models on the basis of its policy of constant improvement.



TOP QUALITY
Teyme equipment offers the highest level of satisfaction thanks to our great level of self-demand.



R&D
Investing on research and development is the basis of our equipment's success.



RESPECTFUL
We care for the Earth, we care for the people.

HIGH PERFORMANCE

VERSATILITY

UNIFORMITY IN PRODUCT DELIVERY

SYSTEM AGAINST COMPACTNESS OF PRODUCT

TEYME

TDTSS700.E / 1021

DTSS 700

TECHNICAL AND MECHANICAL FEATURES



FRAME

Strong sturdy frame with universal coupling system for kits with several applications. Retractable footstep in order to have access to the filling area. Depending on the kit to be assembled, upper iron arches for reinforcement of the structure are included.

HOPPER

Made of steel 700L.
Designed in order to reach a complete emptying.
Especially suitable for Big Bag's.
Sieve against lumps also acting as safety grid according to EC regulations.



SYSTEM AGAINST COMPACTNESS

Spinning mixing blades triggered by hydraulic system
This system enables to keep the product in perfect condition for an effective treatment from the beginning to the end.

DISCONNECTER (in option)

It allows mixing blades to work separately from the feeding system.
This option is extremely useful during the machine's journeys because meanwhile it keeps the homogeneity of the product avoiding compactness.



ADJUSTABLE CONTROL

Hydraulic control from the tractor, dosage from 12 to 45 kg/Ha.



AIR/POWDER OUTLETS

With universal coupling device to mount distributors of 1, 2, 6 and 8 outlets.



AIR UNIT

Gearbox. Speed Ratio: 1/7
Polyamide glass fibre fan in Ø400 and 500 mm
Aerodynamic blower-housing in one single piece with two air inlets.

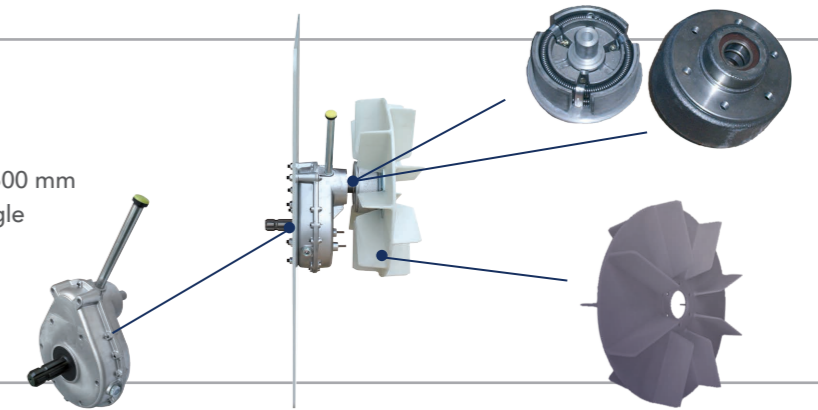

ADJUSTABLE FEEDING

Adjustable feeding by means of a worm gear shaft triggered hydraulically, which enables a highly accurate dosage and full emptying.

