

# PNEUMATIC AND VINEYARD SPRAYERS SERIES

## ZEFIR AND DTVS



- HOMOGENEITY IN TREATMENT
- DEEPEST PENETRATION
- REDUCTION OF PHYTOSANITARY PRODUCT
- MINIMAL DRIFT

**TOP QUALITY**  
Teyme equipment offers the highest level of satisfaction thanks to our great level of self-demand.

**R&D**  
Investing on research and development is the basis of our equipment's success.

**RESPECTFUL**  
We care for the Earth, we care for the people.

### PERFORMANCES TABLE

BTT2-500 AIR UNIT

GEAR BOX SPEED		1 : 6,5		1 : 7,5	
		I		II	
r.p.m					
400	m³/h	11.000		13.400	
	m/s	58		68	
	HP   kW	21	15	29	21
500	m³/h	12.500		15.100	
	m/s	67		76	
	HP   kW	29	21	39	29
540	m³/h	13.800		16.300	
	m/s	70		82	
	HP   kW	35	26	49	36



### DIMENSIONS

Lift-mounted Models	L mm	W mm	H mm	Tare kg
DTVS 400*	1.670	1.220	1.240	262
DTVS 600*	1.670	1.220	1.435	267
DTVS 800*	1.760	1.700	2.050	375
DTVS 1000*	1.760	1.700	2.050	383
DTVS 1200*	1.760	1.700	2.050	391

Trailed Models	L mm	W mm	H mm	Tare kg
Zefir 800 E*	3.088	1.188	1.700	580
Zefir 1000 E*	3.343	1.188	1.700	693
Zefir 1000*	3.135	1.295	2.370	742
Zefir 1500*	3.675	1.464	2.500	856
Zefir 2000*	4.050	1.515	2.800	980

\*Base equipment without kit

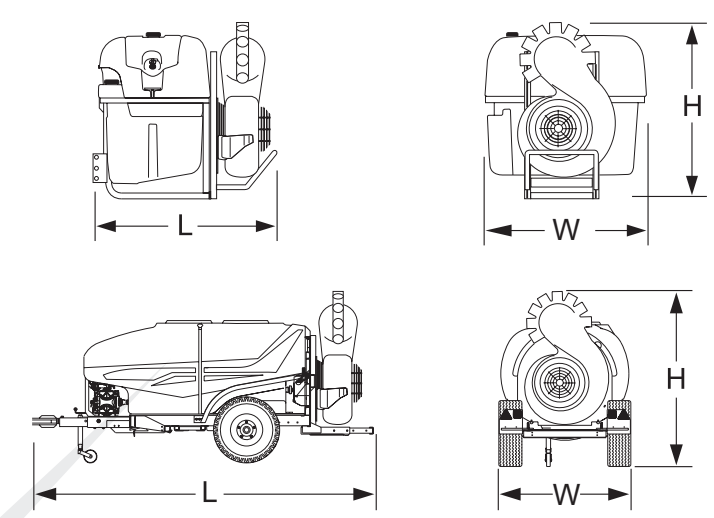

### V-X SYSTEM

**Focused treatment in V-shape:**  
It creates 2 spraying curtains with a 35-40° angle. The vegetation is attacked diagonally achieving a full distribution and coverage.

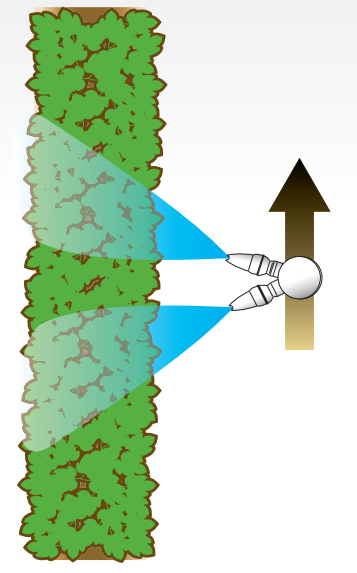
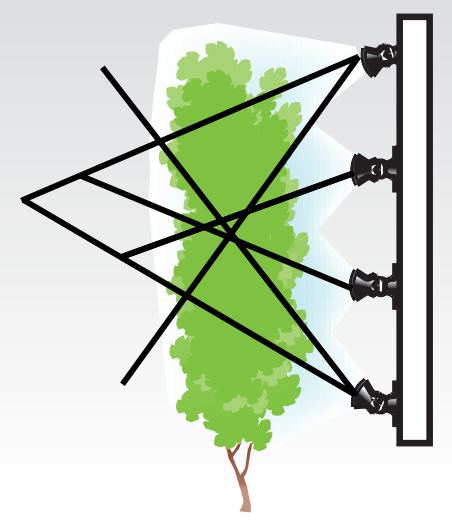

**Focused spraying in X-shape:**  
The air flows cross and overlap one with each other in X shape, treating the vegetation from different angles, obtaining a proportional distribution and full coverage.

### AIR UNIT



#### AIR UNIT BTT 2-500

- **Top performing** air unit with blower housing made of polyethylene and 16.300 m3/h as the highest flow rate.
- **Gear box** with 2 speeds and neutral point.
- Automatic **clutch** with progressive starting and stopping.
- 500 mm **double fan**.

### TEYME'S RANGE OF PRODUCTS

- Mistblowers
- Pneumatic sprayers
- Dusters
- Boom sprayers
- Sprayers
- Humidification and ventilation



Pol. Ind. SAU III · C/ Girona, 2  
25131 TORRE-SERONA (Lleida) · SPAIN  
T: (+34) 973 75 00 33 · F: (+34) 973 75 15 81  
comercial@teyme.es  
www.teyme.es



DEALER:

TEYME reserves its own right to modify, without prior notice, features and performances of the models on the basis of its policy of constant improvement.

TZEFIRDTVS E / 1022



## EQUIPMENT

# ZEFIR



The range of TEYME pneumatic and vineyard sprayers, DTVS (lift-mounted machines between 400 and 1200L) and ZEFIR (trailed machines between 1000 and 4000L) are designed for crops of **integrated production**, where the biological balance between the area and the culture requires to be maintained, achieving an exhaustive control of the use of phytosanitary product and, at the same time, an effective and uniform distribution on all the vegetation surface.

## SPRAYERS' KITS

### VARIABLE GEOMETRY KIT 4 AND 6 COLUMNS



The exclusive system of variable geometry boom allows controlling the lifting and folding of the arms, easily enabling the manoeuvrability of the equipment in the heads of the vineyard as it allows going over that one.

Booms available in 4 and 6 columns.  
The working width is from 1,8m until 3,2m.

# DTVS



## 4-6 SIDES KITS

### "B" KIT WITH 4 COLUMNS

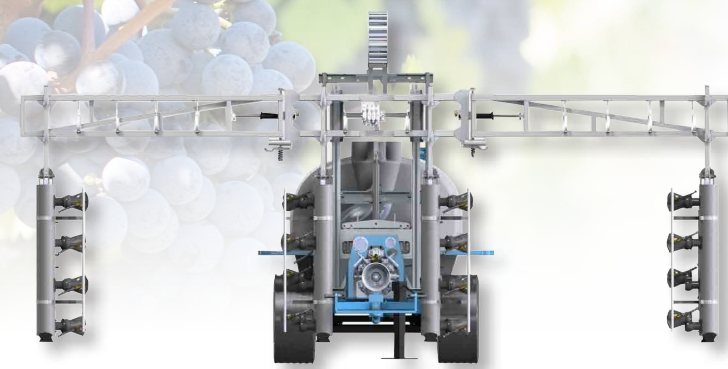

The kit has available **pendulous columns, against bumping and with backwards return movement.** Moveable to fit into vineyards from 2,5 until 3,5 meters.

### "B" KIT WITH 6 COLUMNS

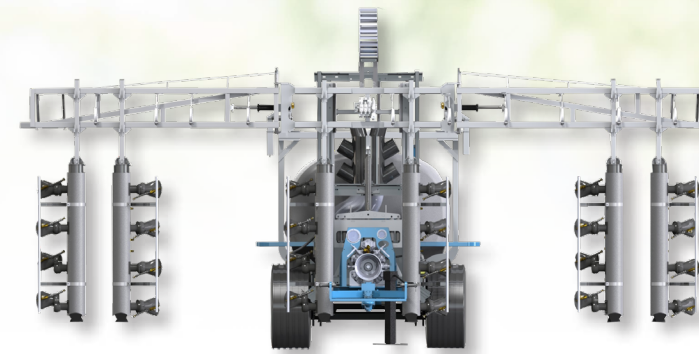

As a latest design, TEYME presents the GALIA special columns, assembled with 160 mm diameter **rigid pipes** with air tank effect. Fully homogeneous regulation of air exit.

### OPTION KIT "A" INCLUDES KIT TERRACES

TEYME's special design kit for vineyards. Triggered with parallelogram system. It allows to regulate the height of the sides in a synchronized way with a height difference of 500 mm. Triggered by a hydraulic cylinder with blockage valve.

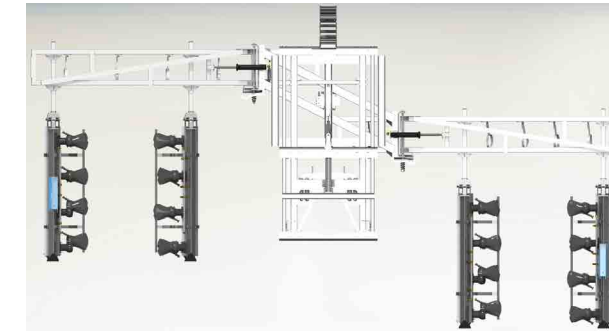

### 8 OUTLETS KIT (4 CENTRAL + 4 CANNONS)

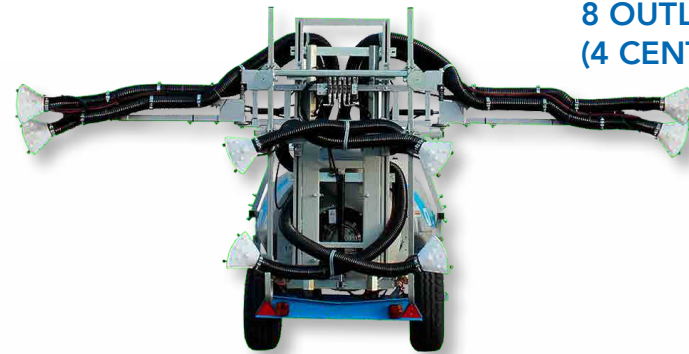

### 8 SIDE OUTLETS KIT (4 COLUMNS)

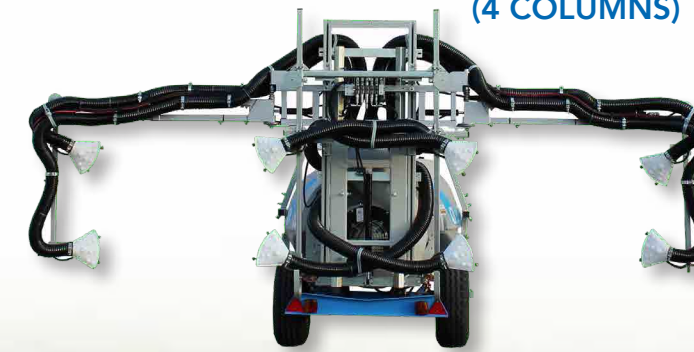

### 4 OUTLETS KIT



Application over 4 sides for trellis vineyards. Treatment focused over the **4 application lines.** Hydraulic or manual lifting and opening.

## 2 SIDES KITS

### ENATE KIT 4 AND 6 OUTLETS

Application focused over 2 sides with treatment row by row suitable for trellis vineyard. Height and spouts manually adjustable. Provided with 4-6 fan spouts.

Suitable for all the range of ZEFIR trailed machines and all the lift-mounted DTVS ones.



### PENEDÉS KIT

Penedés kit with telescopic arm opening and retractable column, 8 flat spouts, 16 nozzle-holders with ceramic nozzles, for vineyard treatments on 2 complete rows between 1,8 m and 3,2 m.



### PROVENCE KIT

Provence kit with telescopic arm opening and collapsible boom end, 6 pneumatic fan spouts and 4 pneumatic cannons, for vineyard treatments on 4 sides between 1,8 m and 3,2 m.



### ROW CROPS KIT

Special equipment for focused treatments on outdoors row crops as well as in greenhouses.

The machine allows hydraulic folding and lifting. The booms allow us to do treatments up until 10m.

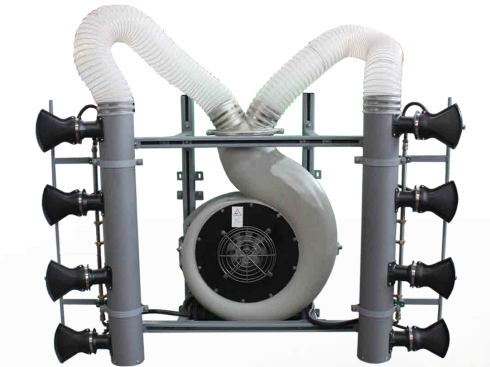

### "D" KIT 2 COLUMNS

"D" kit with 2 central columns, 4 spouts each one and 8 nozzle-holders with ceramic nozzles for treatments on 2 sides.

